

# Practical Noise-Figure Measurement and Analysis for Low-Noise Amplifier Designs

Application Note 1354

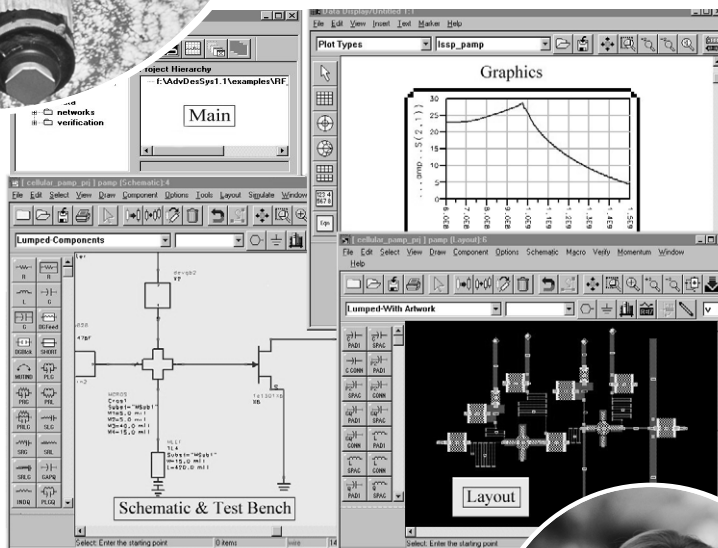

**Agilent Technologies**  
Innovating the HP Way

# Table of contents

<b>Introduction</b> .....	2
<b>The design process</b> .....	3
Software modeling .....	3
Functional requirements .....	3
Selecting a device .....	4
Raw device modeling .....	4
Device matching .....	5
Design completion .....	5
<b>Design verification</b> .....	6
Performance simulation .....	6
Layout and prototype .....	6
Design fine-tuning .....	7
Performance measurements .....	7
Network measurements .....	7
Narrow band NF measurements .....	8
Receiver sensitivity .....	8
Why measure narrow band NF? .....	8
Narrow band example .....	9
Measuring narrow band NF .....	9
Microwave NF measurements .....	10
Swept LO .....	10
Swept IF .....	11
Mixer and receiver NF measurements .....	12
<b>Measurement uncertainty</b> .....	13
Extraneous signals .....	13
Nonlinearities .....	14
Instrumentation uncertainty .....	14
Excess noise ratio (ENR) uncertainty .....	15
Mismatch uncertainty .....	15
Instrument architecture uncertainty .....	16
Instrument NF .....	16
Unwanted in-band power .....	16
Overall uncertainty .....	17

# Introduction

Understanding and accurately measuring noise figure (NF) in low-noise elements has become particularly important to the development of next-generation communications systems. This application note examines the process of making practical noise-figure (NF) measurements of low-noise amplifiers (LNAs) – a capability that can have a significant impact on cost, performance, and required design time for wireless receivers.

The examination begins by looking at a representative LNA block design. Software simulation is leveraged as a vehicle for demonstration and provides a benchmark for subsequent NF measurement and analysis. The design example reveals the typical steps required to take an LNA block from concept to production. At the prototype stage, actual NF measurements can be taken, and the data compared with simulated performance.

For nearly 20 years, standard techniques and methods for measuring the NF in LNAs for wireless receivers served the emerging commercial industry well, and have remained relatively unchanged. But over the past few years, the performance of RF systems has improved significantly, placing tighter limits on NF specifications and greater measurement accuracy. Some of the important features available in contemporary NF analyzers are presented.

Going a step further, narrow bandwidth NF measurement concepts and requirements are introduced. For instance, a bandpass filter is combined with an amplifier block to yield a suitable method for making a practical narrow-band measurement. Further, NF measurements for frequency-conversion devices and systems are explored, as well as consideration of various options for measuring NF at microwave frequencies.

As the performance of RF devices continues to improve, assessing NF measurement uncertainty becomes increasingly valuable. The primary components affecting ambiguity in measurement are presented, as well as a useful methodology for approximating the overall effect of measurement uncertainty.

# The design process

LNA design typically begins by assessing functional requirements for the application. Candidate devices are then selected based on specifications including NF, stability, unilateral gain, and dynamic range. The actual design work starts with S-parameters and choice of an appropriate bias technique for the device, followed by synthesis of matching networks. Layout includes choosing vendor-specific parts, adding interconnections and pads, followed by floor planning. The performance is then analyzed, and the design is optimized to assure requirements can be met using specific vendor parts. Finally, the overall design is reviewed.

## Software modeling

The development of cost-effective amplifier designs for wireless communications systems would be virtually impossible without the use of advanced software-based modeling technology. Today's high-caliber tools typically provide an easy-to-use hierarchical, windows-based user interface as illustrated in Figure 1.

# Functional requirements

For illustration, the example amplifier is intended for a handheld phone application, and will require a general low-noise receiver front-end to cover the 1.8GHz and 2.3GHz mobile phone bands. Additional functional requirements are listed below.

- Frequency range: 1.5-2.5GHz
- NF: <1dB
- Gain: >10dB
- VSWR: <2.0:1
- Supply voltage: 3V

The sub 1dB NF is important in this application, taking on even greater importance than voltage standing wave ratio (VSWR). However, a VSWR of 2.0:1 or better is still highly desirable. Since the design is intended for a portable device, low voltage operation using a 3-volt battery is required. Cost is also a key constraint, while space is slightly less critical. A distributed, microstrip matching circuit will therefore be used to minimize component count.

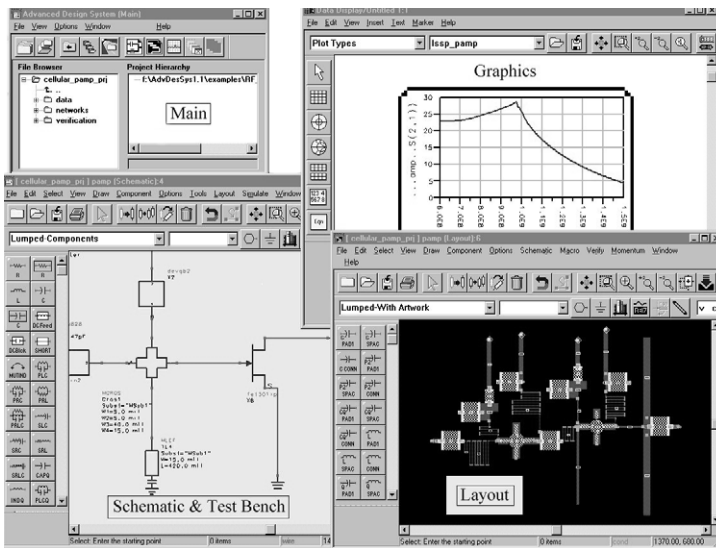

Figure 1. Tools such as Agilent's Advanced Design System (ADS) provide an intuitive, windows-based interface. Throughout this document, ADS is utilized to demonstrate all models, schematics and simulation results. The Main window in ADS, shown at the upper left, serves as a file manager and a portal to other ADS windows such as the Layout or Schematic & Test Bench windows. The Graphic Server window (upper right) offers a visual means of viewing, printing, and analyzing data from completed simulations.

## Selecting a device

Although an array of process and device technologies may be suitable for the intended application, the selected device for this example is an ultra low-noise amplifier fabricated in a pseudomorphic high-electron mobility transistor (PHEMT) gallium arsenide (GaAs) process. The device features 0.5dB NF, +14dBm third-order intercept point, and 17.5dB gain at 2GHz, 4V, 60mA. The transistor is optimized for 0.9GHz to 2.5GHz cellular PCS low-noise amplifiers (LNAs). The wide gate width of this device exhibits impedances that are relatively easy to match, and the 1dB NF requirement should also be easy to meet. The S-parameters and noise parameters for this device are shown in Figure 2.

! ATF-34143		S PARAMETERS									
! Id = 20 mA		LAST UPDATED 2/6/99									
!FREQ	S11		S21		S12		S22				
	!GHZ	MAG	ANG	MAG	ANG	MAG	ANG	MAG	ANG		
0.50	.96	-37	10.08	153	.035	68	.4	-35			
0.80	.91	-60	9.642	137	.050	56	.34	-56			
1.00	.87	-76	8.867	126	.061	48	.32	-71			
1.50	.81	-104	7.443	106	.077	34	.29	-98			
1.80	.78	-115	6.843	98	.083	28	.28	-110			
2.00	.75	-126	6.306	90	.088	23	.26	-120			
2.50	.72	-145	5.438	75	.095	15	.25	-140			
3.00	.69	-162	4.762	62	.102	7	.23	-156			
4.00	.65	166	3.806	38	.111	-8	.22	174			

!FREQ	!GHZ	Fopt dB	GAMMA OPT		RN/Zo
			MAG	ANG	
0.5		.10	.90	13	.16
0.9		.11	.85	27	.14
1.0		.11	.84	31	.13
1.5		.14	.77	48	.11
1.8		.17	.74	57	.10
2.0		.19	.71	66	.09
2.5		.23	.65	83	.07
3.0		.29	.59	102	.05
4.0		.42	.51	138	.03

Figure 2. S-parameters and noise parameters for the ultra-low noise transistor in the design example (the Agilent ATF-34143). The file, as shown, is downloadable from the Agilent website formatted for use directly with ADS.

## Raw device modeling

The schematic of the amplifier device, shown in Figure 3, reveals some source resistance for self bias. This configuration forces the gate negative with respect to the source, allowing the drain current to be set with the source resistor ( $R_s = V_{gs}/I_d$ ). This simple biasing technique is very appealing, since it reduces the overall parts count. The source resistor is AC bypassed, using a low-impedance capacitor with the desired operating frequency.

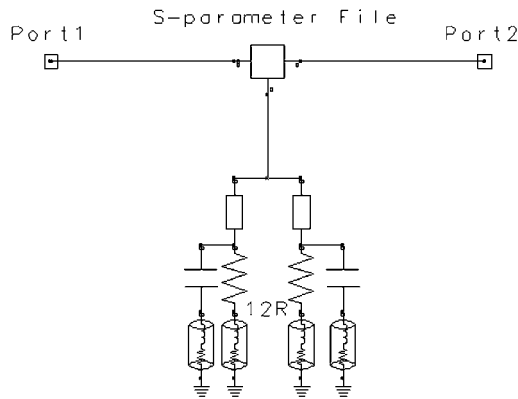

Figure 3. This is the basic schematic of the amplifier using the ultra-low-noise ATF-34143 transistor. The model represents the raw device with source resistance indicated for a self-biased condition.

The model accounts for through-hole vias and selected source inductances produced by the printed circuit board. Some source inductance can be beneficial, because of its impact on input impedance and low-frequency stability. On the other hand, too much inductance can cause high-frequency gain peaking, which results in oscillations. With an 800 micron gate width, the device in the example design exhibits reasonable tolerance to these effects. However, these parasitics need to be included in the model since they affect input and output impedance, which must be matched.

The Smith chart in Figure 4 provides a convenient way to examine the various impedances for the target device, which in turn can be leveraged to synthesize an appropriate matching network.

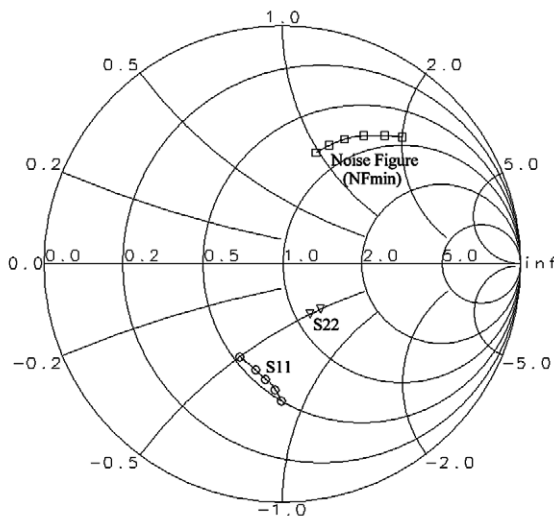
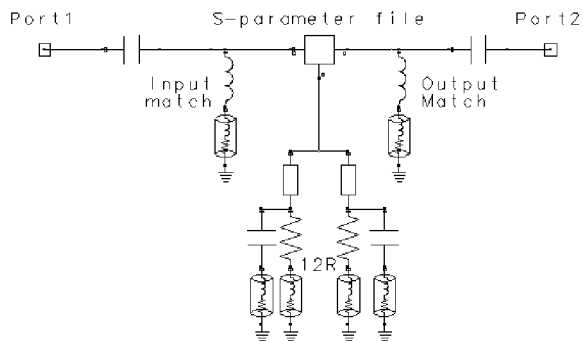

Figure 4. Simulated noise and S-parameters for the transistor model, with S11, S22 and NFmin plotted on a Smith chart.

## Device matching

From the Smith chart it is clear that the device exhibits some capacitive behavior. Therefore, the matching network can be a simple high-pass impedance circuit fashioned from a series capacitor and shunt inductor as seen in Figure 5.



**Figure 5.** Since the device is capacitive, a simple high-pass impedance circuit can be used for the matching network.

The high-pass topology is especially well suited for personal communications services (PCS) and wireless LAN applications since it offers sufficient low-frequency gain reduction, which can minimize the amplifier's susceptibility to cellular and pager transmitter overload. A similar high-pass structure is used for the output impedance matching network, which is optimized for best return loss and output power.

There are a number of options to determine component parameters for the matching network. Manual calculation using the device's impedances represents the most basic approach. Alternately, while most engineers are reluctant to use the Smith chart, it provides a simple, intuitive way of manipulating impedance, and therefore developing matching networks. Modeling software is another method of synthesizing and optimizing matching networks based on input and output impedances.

## Design completion

After the initial optimization, finishing touches can be made to the amplifier model. Inductors are replaced with distributed elements and discrete components are replaced with parts from vendor libraries as seen in Figure 6.

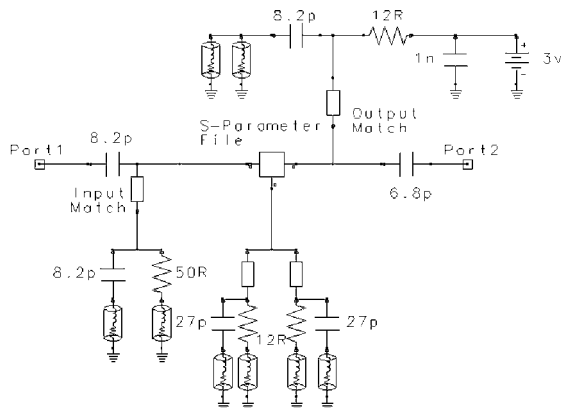

**Figure 6.** Here are the synthesized matching circuits for the ultra-low-noise transistor example. After requirements for input and output return loss, NF and gain are entered, the software optimizes matching circuit parameters for best results. Inductances are substituted with distributed elements and discrete components are replaced with behavioral models of actual parts from vendor libraries.

The 50 $\Omega$  resistor between the input inductor and ground provides a DC return for the gate terminal of the device. This also supplies an effective low-frequency resistive termination for the device, which is necessary for stable device operation. In addition to being part of the matching network, the output inductor doubles as a way of decoupling the power supply.

With all components defined and the effects of through-hole vias included in the model, the circuit is once again optimized and its performance is assessed. At this point, parameters and components can be re-tuned if required.

# Design verification

## Performance simulation

When the finished design is simulated, it looks like the effort is on track so far. NF for the amplifier easily meets the requirement of less than 1dB, peaking at around 0.85dB as seen in Figure 7. The design also supplies adequate gain. Input and output VSWRs are also entirely respectable, although they do peak at the specified upper limit of 2.0:1.

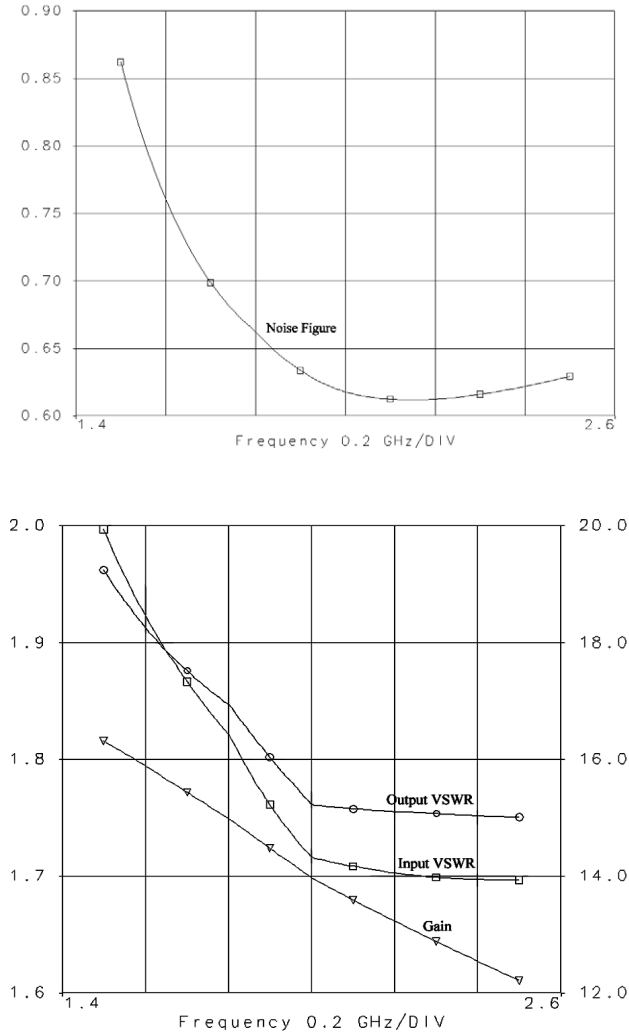

Figure 7. These plots show simulated NF as well as gain and match for the finished amplifier design.

## Layout and prototype

No matter how good simulations look, the ultimate goal is a working circuit. Simulations are wholly dependent on the accuracy of device models – they cannot replace actual measurements on real circuits. Simulation is merely a tool that speeds up the design process. The real ‘proof of the pudding’ is in the prototype circuit.

Creating the prototype starts by generating a layout for the amplifier as shown in Figure 8. Once the schematic is imported into a layout tool, such as the Layout module in ADS, components, grounding planes, and transmission lines are placed. The distributed inductors, which can clearly be seen in Figure 8, were intentionally made longer than required to enable later modification.

Layouts created in one software modeling tool can usually be ported to other tools. This simplifies the task of developing sub-systems of a design independently, for later integration. The layout shown in Figure 8 was used to build the finished prototype in Figure 9.

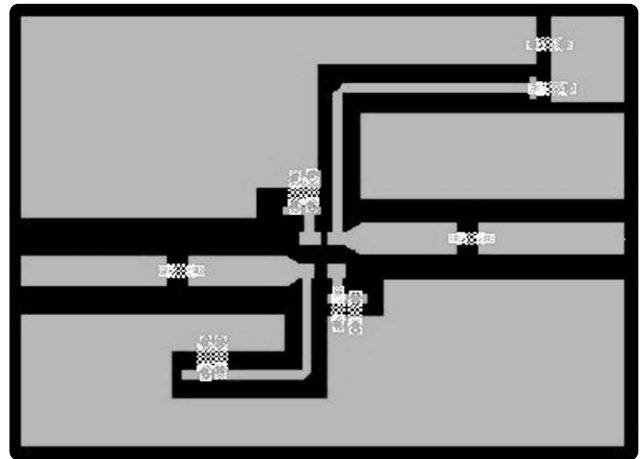

Figure 8. This layout was generated in a layout tool directly from the schematic. The layout was printed on high-quality film using a standard inkjet printer, which was then used to produce the PCB from Rogers 4350 material for the prototype.

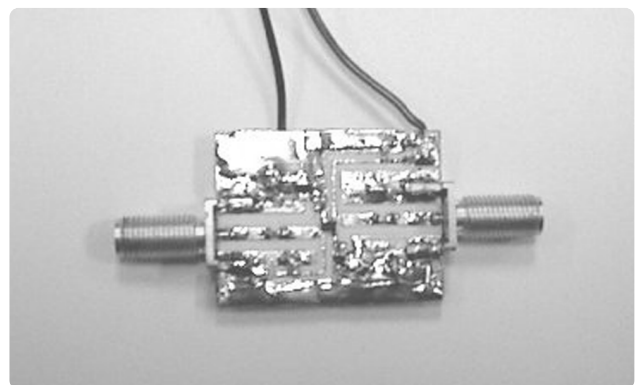

Figure 9. The prototype amplifier.

## Design fine-tuning

### Performance measurements

Now the initial design work can be verified. In this example, Agilent's N8973 Noise Figure Analyzer is used to measure the performance of the prototype. First, the analyzer is configured for a 1.5 to 2.5GHz sweep and calibrated. This is accomplished by feeding the noise source directly into the instrument. The analyzer then measures its own noise figure at various attenuator settings. This is used in the corrected measurement to remove the effects of the analyzer.

Once calibration is complete, corrected measurements for NF, Y-factor, gain, and effective temperatures, can be executed with the prototype amplifier connected between the noise source and the instrument. Figure 10 shows the actual screen capture of the NF as measured and plotted by the analyzer.

Unfortunately, the measured performance falls short of what was predicted by simulation. The NF peaks at over 1dB at the band edges. On the other hand, performance results at the middle of the frequency range is quite good, at less than 0.7dB. The effects of nearby mobile phones can also be seen on the plot, which is to be expected when measuring an unshielded circuit.

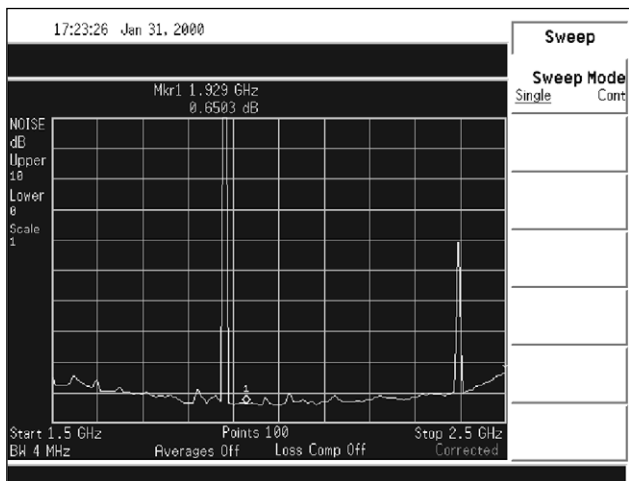

Figure 10. Screen capture of the measured performance of the amplifier prototype plotted on a noise figure analyzer. The data is corrected for second-stage effects generated by the analyzer.

The measurement results don't tie directly back to the simulation results, but they do provide a good starting point for further improvement to the design. In any case, the design must be modified in order to meet the required specifications.

A number of parameters can be altered to reach the desired results, including changing component values or trace dimensions. The strategy of using distributed elements may even be suspect, being replaced with a scheme that uses lumped elements with higher Q values instead. Once any of these modifications are made, changes in performance can be monitored using the analyzer and added to the simulation for the next design iteration.

### Network measurements

Simulation software can also ease the task of gathering and analyzing data from measurement instruments. Contemporary simulation tools generally include some form of general purpose interface to enable the transfer of data with measurement instruments. This feature was used to capture the measured S-parameters from a network analyzer for the amplifier example.

The plot in Figure 11 shows the gain and VSWRs of the example amplifier. The gain easily meets the 10dB requirement, but the VSWRs are a bit on the high side at the low frequency end of the band. This is probably tolerable since the intended frequency bands are 1.8 and 2.3GHz. The required design iteration could very well improve this situation.

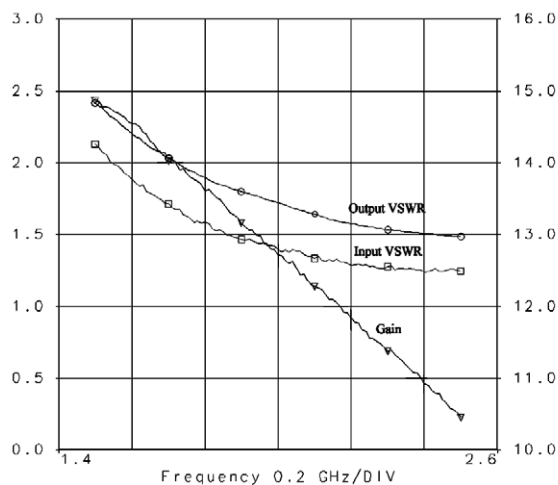

Figure 11. Gain and match ported to ADS, and plotted to simplify analysis.

## Narrow band NF measurements

Due to the random nature of noise, noise-power measurement accuracy improves as bandwidth or noise exposure time increases, and both parameters have an averaging effect. In addition, the cumulative average of many measurements can be calculated to increase accuracy even further.

Noise-exposure time is a fixed value in NF measurement equipment. Earlier NF measurement instruments also had a fixed value of 4MHz for band-width, while their primary use was for defense applications – in particular, radar. This provided a good trade-off between measurement time and accuracy for a given number of averages.

For scores of modern applications, a 4MHz bandwidth is still acceptable for NF measurements. However, the explosion in wireless communications and increasing congestion in the radio spectrum have increased the need to assess NFs over much narrower bandwidths. The following example will help illustrate this point.

### Receiver sensitivity

Figure 12 is a simplified representation of a receiver front-end for a mobile phone or base station application. Good receiver sensitivity is extremely important, since it enables detection and resolution of weaker signals. As receiver sensitivity increases, transmitter power can be reduced, which leads to benefits such as smaller phones and increased battery life.

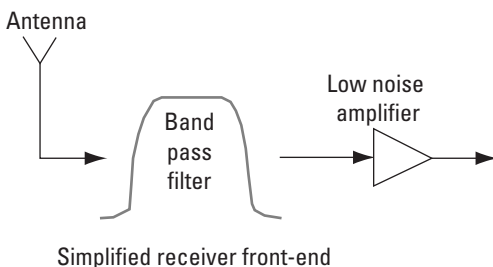

Figure 12. Simplified receiver front end for a mobile phone or base station application.

A direct correlation exists between receiver sensitivity and NF (i.e., if NF is reduced by 1dB the receiver gains 1dB of sensitivity, or vice versa). With receiver sensitivity representing a key metric for product differentiation between manufacturers and service providers today, NF has become an extremely important parameter.

As shown in the receiver model, the signal enters the system via an antenna. Generally, the signal is then passed through an isolation stage to provide a good match to the amplifier, and possibly split the transmit and receive paths. Next comes a bandpass filter to separate the image frequency and remove any adjacent high-power signals.

The critical low-noise amplifier, usually with a NF of 0.5dB or better, follows the bandpass filter stage. The gain of this amplifier effectively helps to overcome any NF added by subsequent stages, thereby making them less critical in terms of NF, but not insignificant.

### Why measure narrow band NF?

Figure 13 illustrates the layout of the GSM (global system for mobile communications) band, the world's leading mobile phone service. Transmit and receive bands are each 25MHz wide, spaced 20MHz apart. As shown, the receiver input filter must pass the entire 25MHz band.

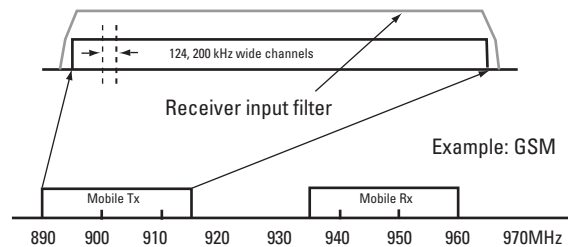

Figure 13. Example GSM signal arrangement.

A GSM base station must accommodate a very sensitive receiver and a high-power transmitter (maybe on the order of 50dBm) in the same location. The signals are separated by little more than 20MHz. Plus, there are likely to be other high-power transmitters for different wireless services at the same location.

In order for the receiver to effectively perform its function, the input filter must deliver extremely sharp roll-off characteristics coupled with robust out-of-band rejection capabilities. Cavity-type filters are generally employed for these applications.

The 25MHz wide GSM band is split up into 124, 200kHz-wide channels. With a cavity-type filter at the receiver front-end, the filter roll off can potentially impinge on the channels at the edges of the band. If this happens, it would cause signal loss in these channels before the amplifier, resulting in higher NF and rendering them less effective than mid-band channels. Thus, system developers must be able to measure NF of specific channels – not just the overall band.

## Narrow band example

Let's take a look at a narrow-band example. For this demonstration, a SAW filter is combined with a mini-circuits amplifier block as shown in Figure 14. This arrangement yields an amplifier with approximately 440kHz of bandwidth. The NF of this arrangement is high, due to approximately 8dB of loss from the SAW filter, but the example still serves as a good illustration. In a real-world application, a filter with low loss in the passband would be used to minimize NF.

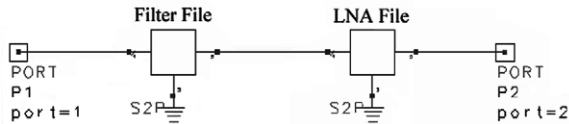

Figure 14. The narrow-band amplifier example combines a SAW filter (~440kHz) with an LNA.

The gain of this filter-amplifier combination measured on a network analyzer is around 14.5dB as seen in Figure 15, which serves as a reference. Intuitively, a plot of NF would roughly be the inverse of the network plot (i.e., the NF is low where the gain is high, and vice versa). In a real design, this filter-amplifier combination would be modeled, optimized for lowest NF, prototyped, measured, and then fine tuned to meet all specifications for the design.

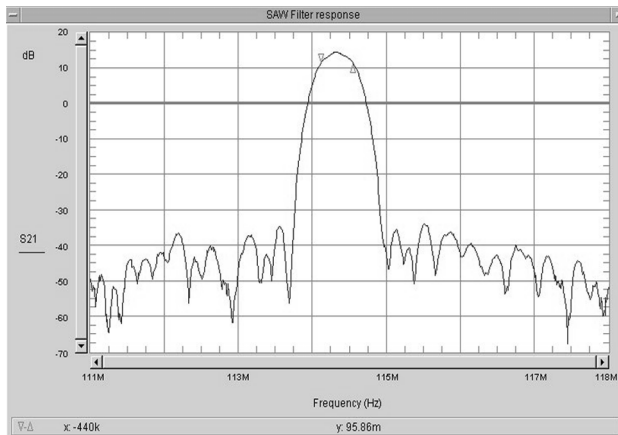

Figure 15. Checking the response of the narrow-band example circuit on a network analyzer reveals about 14.5dB of gain over 440kHz of bandwidth.

## Measuring narrow band NF

Figure 16 shows the measurement results of the narrow-band amplifier using the standard 4MHz of noise bandwidth afforded by older noise figure measurement instruments. The frequency response shown here is significantly different from that measured using the network analyzer. The gain is much lower and the NF does not have the expected inverse shape.

There are two reasons for this. First, the DUT's bandwidth is much narrower than the measurement bandwidth, resulting in a linear convolution between the instrument's frequency response and the DUT's frequency response. The same effect occurs on a spectrum analyzer if the IF bandwidth is not chosen correctly, resulting in a plot of the IF filter response rather than the response of interest.

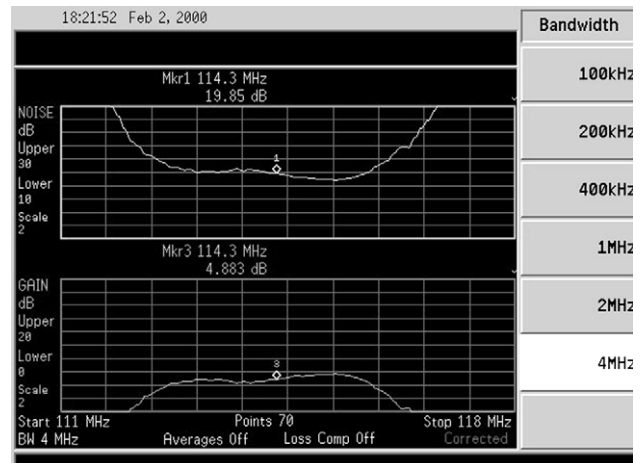

Figure 16. Narrow-band amplifier gain and NF measurements using the customary 4MHz noise bandwidth.

The second reason for the measurement difference is that the band-pass filter does not shape the noise floor of the amplifier the same way that it shapes the signal level or, in the case of a noise-figure measurement, the hot noise power from the noise source. Although the noise power entering the instrument is in a narrow band, since the instrument observes this power over 4MHz, it calculates a lower dBm/Hz value. This results in a NF plot with the wrong shape and an artificially high value.

The plot in Figure 17 shows the same measurement using a narrower 100kHz bandwidth – more than four times less than the DUT's bandwidth. Here, frequency response is closely correlated with the previous network measurement. Also, NF is much lower and exhibits the expected shape.

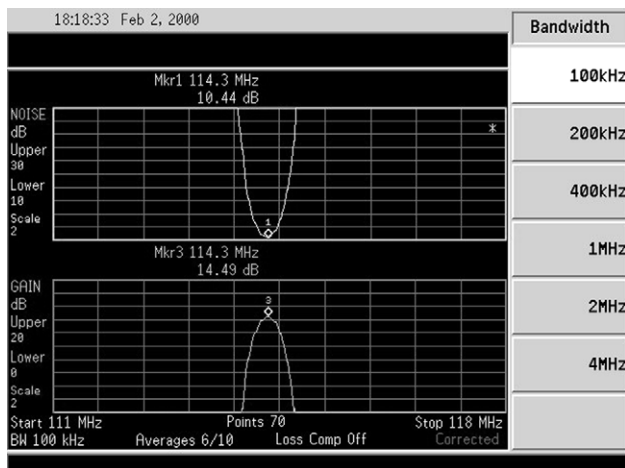

Figure 17. Narrow-band amplifier gain and NF measurements using a 100kHz noise bandwidth.

With older NF analysis equipment, true results are very difficult to achieve, and the resulting uncertainties make them unrealistic for measuring modern devices. The Agilent N8973 NFA makes the measurement easy, however, as with all noise measurements, there is a time penalty that must be paid for making accurate narrow bandwidth measurements.

## Microwave NF measurements

Modern measurement instruments easily handle frequencies up to 3GHz. Above that, signals can still be measured with the aid of an external mixer, local oscillator, and filters. The mixer can down-convert a microwave signal to a frequency that can be handled by the analyzer. If the analyzer has a second interface port, it can be used to control the frequency and power level of a signal generator, which serves as the LO (local oscillator).

Microwave measurements are a bit more difficult. Systems can employ single-sideband (SSB) or double-sideband (DSB) measurements. It is also important to make sure that the LO frequency does not appear in the pass band of the instrument, since high LO leakage power (relative to noise) from the mixer is likely to cause the analyzer to range incorrectly. When choosing an LO, it is important to choose one that exhibits low phase noise. Otherwise, filters will be required to ensure that the phase noise is not added to the overall system noise figure.

### Swept LO

In the setup illustrated in Figure 18, the LO is configured to sweep synchronous with the input frequency, and the analyzer is set to a fixed IF frequency. After the IF frequency and range are set, the analyzer calculates the frequencies for the LO sweep.

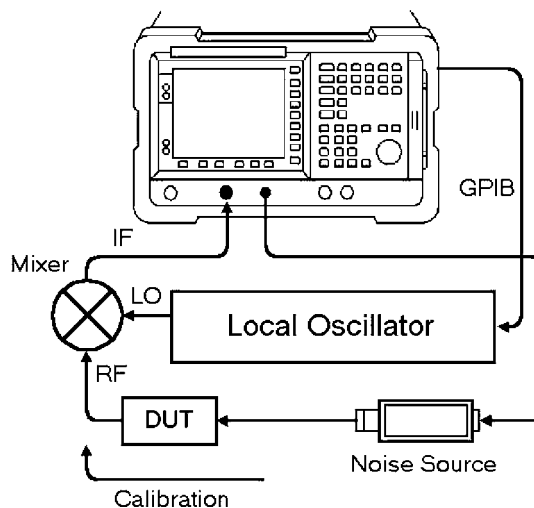

Figure 18. After setting IF frequency and input frequency range, the instrument calculates the LO frequency. Then the instrument is calibrated by connecting the noise source directly to the mixer. After calibration, the DUT is inserted between the noise source and the mixer, and corrected NF and gain are displayed.

Calibration is accomplished in the same way as an RF calibration. The noise source is connected directly to the RF input of the mixer and a user calibration is performed to measure the NF of the entire system, including the mixer, cables, and adapters. The DUT is then placed between the noise source and the mixer and a corrected measurement is made.

DSB measurements are achieved by taking the average of two measurements spaced at twice the IF frequency. A relatively low IF frequency is desirable to keep the measurements close together and minimize the effect of averaging, which increases measurement uncertainty based on how rapidly gain or NF varies with frequency.

There is no need to correct for different power levels of SSB versus DSB measurements, since the total measurement bandwidth is the same for calibration and measurement. The analyzer will display the correct gain and NF values.

SSB measurements can also be carried out with the LO sweep setup, perhaps to remove the effects of averaging. In this case, an appropriate low-pass filter is required between the DUT and the mixer to remove the upper sideband signal, as seen in Figure 19.

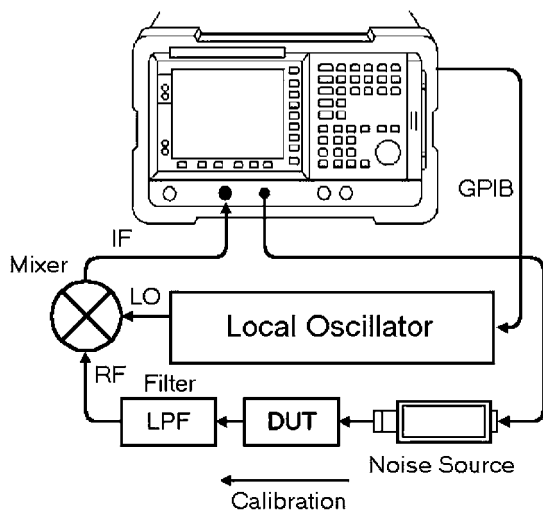

**Figure 19. SSB measurements require the use of a low-pass filter between the DUT and the mixer.**

### Swept IF

It is not necessary to perform measurements using a swept LO. With some instruments, the LO can be a fixed value and the instrument's input frequency can then be set to sweep in synchrony with the input frequency. Once the LO frequency and RF input frequency range are set, the analyzer calculates the frequencies for the IF (instrument) sweep.

Swept IF measurements are only appropriate for SSB measurements, which requires the low-pass filter seen in Figure 19. For example, consider a measurement between 3.7 and 4.2GHz with LO fixed at 3.95GHz. A DSB measurement would yield the same results for the average of the two side bands ( $LO \pm IF$ ), regardless of the IF value.

Calibration of the swept IF setup is the same as swept LO with the exception of the low-pass filter, which must be in place for both calibration and measurement.

## Mixer and receiver NF measurements

The NF for mixers and receivers can be measured using the setup in Figure 20. Calibrating this setup requires an analyzer with a “mixer measurement mode.” Once the instrument is set to the correct IF, LO and input frequencies, the noise source is connected directly to the instrument and user calibration is performed. After calibration, the instrument will not display 0dB plus jitter even without the DUT connected, since the instrument uses the microwave frequency ENR (excess noise ratio), while the input is tuned to the IF.

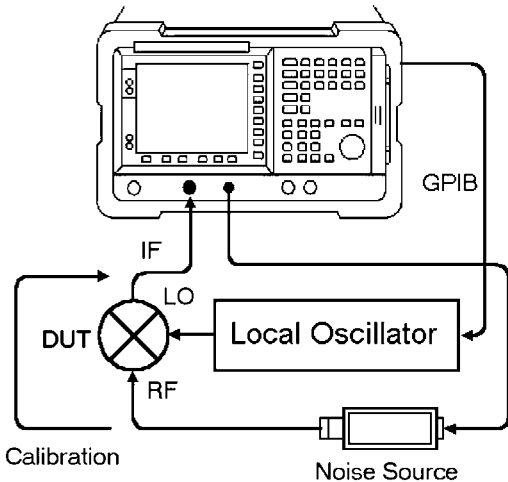

**Figure 20.** Mixers can be measured using either a swept LO or swept IF. With receivers, measurements are performed using swept IF, as the LO is part of the receiver. Both DSB and SSB signals can be measured, but care must be taken when interpreting results. User calibration is performed with the noise source connected directly to the instrument, and the instrument calibrates using ENRs (excess noise ratios) at the IF frequencies. It then uses the ENRs at the RF frequencies during measurement.

When a mixer is connected directly to the analyzer, actual conditions are measured. That is, if the external mixer is configured to reject one side band, a SSB result is displayed. Similarly, if both sidebands are converted by the mixer, a DSB result is displayed. Thus, care should be taken when interpreting results, since confusion can occur if DSB results are used to predict performance of a SSB system.

Also, when making DSB measurements of mixers, receivers, or other frequency-converting devices, the measured gain will be 3dB higher than the equivalent SSB measurement. This is because the measured bandwidth is effectively twice the calibrated value. Similarly, NF will be 3dB low. Some noise figure analyzers may include loss-compensation features that will correct this error, but the correction is only accurate if the gain (conversion loss) in each sideband is equal.

Using a swept IF configuration with the setup in Figure 20, the NF of a complete receiver can be measured, assuming access is available to the receiver IF. Both DSB and SSB measurements are possible.

## Measurement uncertainty

Satellite and mobile communications applications rely on monolithic and discrete semiconductor devices with increasingly-diminishing NFs. This also intensifies the pressure on engineers to reduce NF measurement uncertainty. Many factors can affect the uncertainty of NF measurements, including:

- Extraneous signals
- Nonlinearity
- Instrumentation uncertainty
- ENR uncertainty
- Mismatch
- Measurement architecture
- Instrument NF
- Unwanted in-band power

The following equation can be used to estimate overall NF measurement uncertainty.

$$\left\{ \left[ \left( \frac{F_{12}}{F_1} \right) \delta NF_{12} \right]^2 + \left[ \left( \frac{F_{12}}{F_1 G_1} \right) \delta NF_2 \right]^2 + \left[ \left( \frac{F_2 - 1}{F_1 G_1} \right) \delta G_1 (dB) \right]^2 + \left[ \left( \frac{F_{12}}{F_1} - \frac{F_2}{F_1 G_1} \right) \delta ENR \right]^2 \right\}^{0.5}$$

where,  $F_1$  is the linear noise figure of the DUT,  $F_2$  is the linear noise figure of the noise figure instrument,  $F_{12}$  is the linear noise figure of the complete system (DUT and instrument),  $G_1$  is the linear gain of the DUT, and the  $\delta$  terms are the associated uncertainty terms in dB.<sup>1</sup> In the following sections, the various uncertainty components are explored in more detail.

## Extraneous signals

Pagers, security communication systems, wireless phones, and cordless LANs are all common sources of intermittent and potentially-disruptive signals at rather high power levels (a good illustration of this was revealed in the previous amplifier example). Older computers can also be a problem, while newer designs provide much better shielding. The points at which these signals enter the measurement setup are shown in Figure 21.

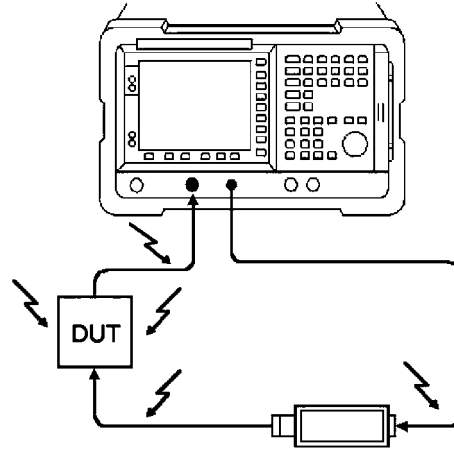

**Figure 21. Spurious noise can enter the test setup from external devices or connected components. Choosing a measurement instrument with good shielding is critical for NF measurements, since DUTs are often connected directly to the instrument. Well-designed instruments will exhibit very low emissions in the near field.**

In some cases these sources must either be removed or the measurement setup moved to a shielded room. Shielding techniques should be designed to reduce extraneous signal levels by 70 to 80dB, particularly near transmitters.

One source that cannot be removed in a shielded room is the measurement instrument. If the DUT is connected directly to an instrument that does not incorporate adequate internal screening, any spurious signals emanating from the instrument increase the uncertainty of the measured results.

For this reason, NF analyzers are typically heavily screened, beyond what is called for by standard far-field EMC emissions qualifications, which are not adequate. Instead, these instruments are normally required to meet much more rigorous near-field emissions specifications.

<sup>1</sup> The derivation of the NF measurement uncertainty equation can be seen in *Microwaves & RF Magazine*, October 1999, available at [www.mwrf.com](http://www.mwrf.com)

## Nonlinearities

It is impossible to measure the NF of a nonlinear device. Noise measurement can only be accomplished when both the hot and cold powers from the noise source are constrained to straight lines. If the DUT behavior is nonlinear, Y-factor is distorted and NF cannot be accurately measured. Figure 22 shows a plot of a device with a degree of compression, resulting in a NF measurement that is too high.

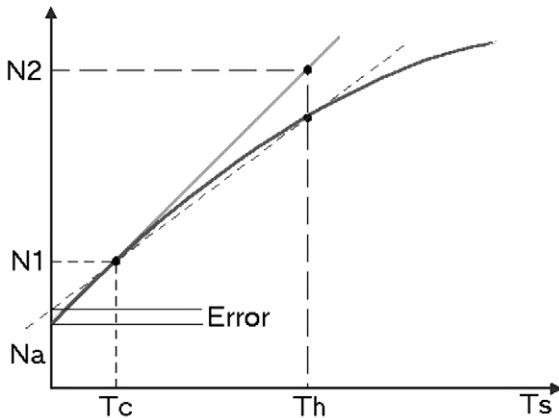

Figure 22. NF measurements appear too high for nonlinear devices.

Elements such as AGC (automatic gain control), regenerative circuits, and limiters (e.g., frequency- or phase-locked loops) add nonlinear behavior to equipment that makes noise characterization virtually impossible. Thus, the NF of sub-systems should be measured before these elements are added.

## Instrumentation uncertainty

The primary component of instrumentation uncertainty is the linearity of the noise power detector. An ideal power detector response would be along the horizontal axis of the graph in Figure 23, which illustrates the behavior of a representative noise figure meter.

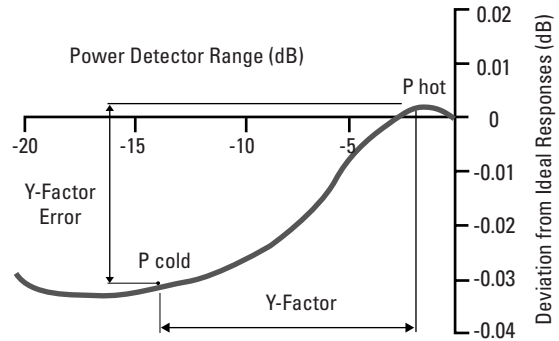

Figure 23. This shows the typical response of the power detector in the Agilent 8970B Noise Figure Meter, which is intentionally designed so that hot noise power falls within the top 5dB window of the detector response. The NF error in a 11dB Y-factor due to nonlinearities is about 30m dB (i.e.,  $NF = ENR - 10 \log(Y-1)$ ), which is actually quite good. Instruments not optimized for measuring noise, such as spectrum or network analyzers, typically exhibit much poorer linearity.

The nonlinear effects of the power detector are present in every calibration and measurement regardless of the DUT's characteristics. This effect can be minimized by choosing a noise source with a lower ENR, which exercises less of the detector's dynamic range and yields behavior that is more linear.

Instrumentation uncertainty is a key measure of the raw performance of NF measurement equipment – differences between instruments as little as 50m dB can have a significant effect on overall measurement uncertainty. This feature should be a primary concern when choosing equipment.

## Excess noise ratio (ENR) uncertainty

The ENR uncertainty of the noise source can be an especially large component of measurement uncertainty. Any ENR error transfers directly to the NF, since  $NF = ENR - 10 \log(Y-1)$ . Typical ENR uncertainty specifications for noise sources are currently around 0.1dB. The plot of a representative noise source is shown in Figure 24.

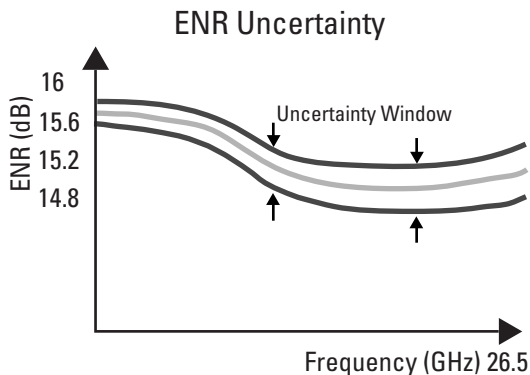

Figure 24. ENR uncertainty in a typical noise source.

Since specifications for ENR uncertainty in noise sources are currently covered by recommendations from the National Institute of Standards and Technology (NIST), there is little that an engineer can do to improve this parameter. At the very least, care should be taken to ensure that noise sources are routinely calibrated and that the proper calibration tables are used.

With previous-generation instruments, calibration tables were entered into the measurement equipment by hand – a process that was both difficult and prone to error. Modern equipment eliminates this source of error because calibration table data is loaded directly from a disk or transferred via a standard interface, which is desirable for production environments.

## Mismatch uncertainty

Noise-power reflections from noise sources and attached devices produce extremely complex effects. The VSWR of the noise source represents a potentially large source of error. Low ENR sources (5dB or less) with higher internal attenuation provide the best accuracy. This is due to lower VSWR and better consistency between on and off impedances.

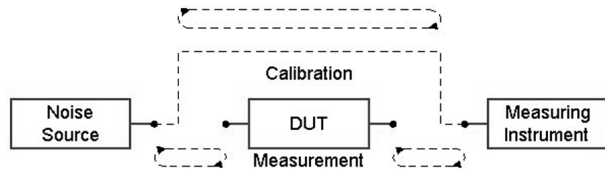

Figure 25. Noise-power reflections can come from external noise sources as well as attached devices, increasing mismatch uncertainty.

Placing isolators on the links between the DUT, the noise source, and the instrument can provide relief from these effects, but the isolators add insertion loss and hence another uncertainty component. DUTs with high gain are more immune to the effects of mismatch uncertainty, since higher gain reduces the relative contribution of second-stage NF from the instrument.

Some manufacturers recommend reducing the effects of mismatch uncertainty through the use of S-parameters. But S-parameters reveal nothing about noise performance. If S-parameters are used without noise parameters they are likely to introduce more errors than they remove, in addition to adding their own uncertainties.

## Instrument architecture uncertainty

The primary ingredient of instrument architecture uncertainty is the frequency translation that must occur to allow the equipment to make measurements at reasonable IF frequencies. The instrument architecture is either SSB or DSB.

The DSB architecture is used for network analyzers, meaning that the power in the unwanted sideband is subsequently measured by the detector. This power cannot be isolated and therefore causes measurement error. This is exactly the same sort of problem encountered when making microwave measurements with external mixers. SSB architectures are immune to this kind of uncertainty because the unwanted sideband is filtered out of the signal.

## Instrument NF

The ratio of system (DUT and measurement instrument) noise factor (linear) to DUT noise factor is expressed as  $F_{12}/F_1$  in the measurement uncertainty equation. This ratio can never be smaller than one, but has a significant effect on overall uncertainty as the value increases above one.

System NF ( $10\log F_{12}$ ) is a function of the instrument's NF, plus the gain and NF of the DUT. Overall measurement uncertainty increases significantly as  $F_{12}$  increases. This problem may be most apparent when using external mixers. In this case, uncertainty can be improved by inserting a low-noise amplifier before the mixer during calibration and measurement. High gain DUTs also reduce  $F_{12}$ , but as the DUT gain increases, the NF of the instrument also increases due to RF ranging.

## Unwanted in-band power

NF analyzers typically include a broadband power detector that monitors the total power entering the instrument. This enables the equipment to select the optimum RF range and maintain linearity. The noise powers entering the instrument are usually very small—on the order of  $-40\text{dBm}$ . High levels of unwanted in-band power will cause the analyzer to apply attenuators and select a poor range for measurement. This can also occur if any device in the system is oscillating due to instability. This effect increases instrument NF and adds to overall measurement uncertainty.

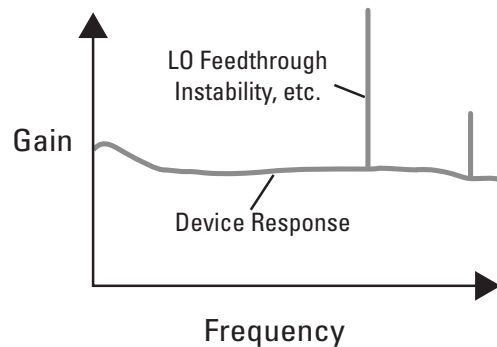

**Figure 26.** High levels of unwanted in-band power will cause the analyzer to select a poor range for the measurement, resulting in a high value for instrument noise figure. This can be avoided by keeping the LO well out of the band of the instrument and ensuring that devices are stable and free of oscillations.

Another situation can arise when measuring modern low-noise devices below their optimum operating frequencies. For example, a GaAs amplifier only begins to perform well above a few 100MHz. Below this point, the NF performance is very poor and gain can peak to rather high levels. This, in turn, increases the power presented to the analyzer, which can result in a less than optimal measurement. Since this kind of amplifier would never be used below a few 100MHz, the frequency response at the low end should be limited, possibly by choosing low value coupling capacitors.

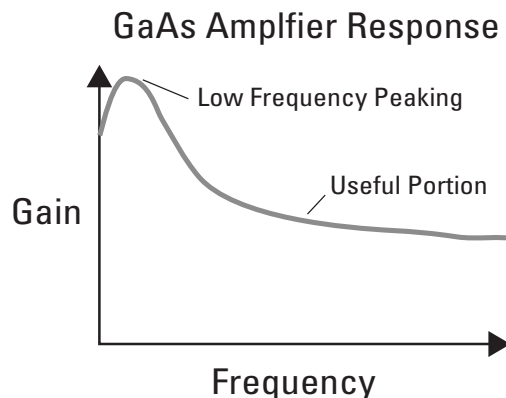

**Figure 27.** Unwanted amplifier response should be filtered.

## Overall uncertainty

As pointed out previously, many components make up measurement uncertainty, and each contributes differently to overall uncertainty depending on specific measurement conditions. Looking at each isolated component provides little value. Rather, the real value is to calculate an aggregate estimate of overall uncertainty, while simultaneously identifying the dominant components to facilitate making improvements.

The previously-discussed measurement uncertainty equation was developed by applying differential calculus to the corrected NF equation  $F1 = F12 - (F2 - 1/G1)$ . This uncertainty equation is available as a web-based calculator for practical use as seen in Figure 28 and Figure 29.<sup>2</sup> This tool enables engineers to quickly assess NF, NF measurement uncertainty, and identify the components that have the biggest effect on overall uncertainty.

The calculator enables various parameters to be swept between two limits, and provides a graphical representation of how overall uncertainty will vary with any chosen component.

Calculator      Tabular Results      Graphical Results

Press this Button to reset the form to default values

Device Under Test  Amplifier  Frequency Converter

Noise Source → [Block Diagram] → Instrument

Noise Source Defaults:		Instrument Defaults:	
346 B	DUT Noise Figure, NF1 (dB)	8970 B	Noise Fig. Uncertainty (+/-dB)
0.1	DUT Gain, G1 (dB)	0.05	Gain Uncertainty (+/-dB)
1.15	DUT Input Match *	0.15	Instrument Noise Fig, NF2 (dB)
	DUT Output Match *	5	Instrument Match *
		1.8	

Parameter      Lower Value      Upper Value      Number of Points

Sweep NONE

\* This term can be entered in dB(Sxx), VSWR or as a reflection coefficient.  
e.g. -15 (dB) = 1.43 (VSWR) = 0.178 (Ref. Coef.)

Figure 28. This is the web-based noise-figure measurement uncertainty calculator data entry window.

Coefficient	Contributors	Contribution (dB)
(F12/F1)	- Mismatch between the noise source and the DUT - Instrument noise figure measurement uncertainty	0.133
(F2/F1G1)	- Mismatch between the noise source and the instrument - Instrument noise figure measurement uncertainty	0.003
((F2 - 1)/(F1G1))	- Mismatch between the noise source and the DUT - Mismatch between the noise source and the Instrument - Mismatch between the DUT and the instrument - Instrument gain measurement uncertainty	0.006
(F12/F1)-(F2/F1G1)	- Noise source ENR uncertainty	0.099
RSS Noise Figure Measurement Uncertainty (+/-dB)		0.165

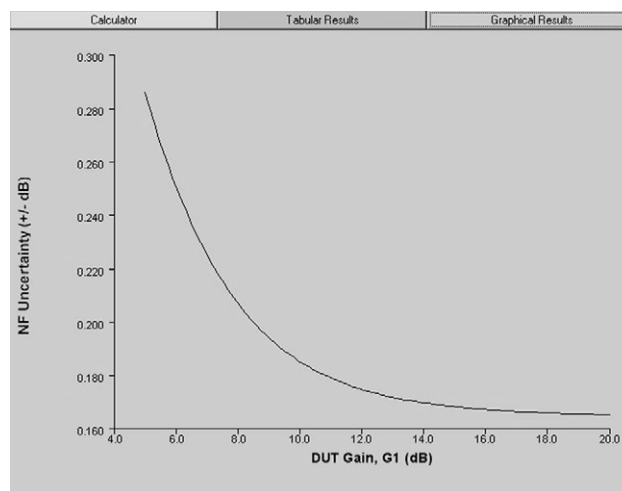

Figure 29. Shown are samples of the results windows for the web-based noise-figure measurement uncertainty calculator.

<sup>2</sup> This web-based NF calculator is available at [www.agilent.com/find/nfu](http://www.agilent.com/find/nfu)

# **-NOTES-**

# **-NOTES-**

**For more assistance with your test and measurement needs go to**

**[www.agilent.com/find/assist](http://www.agilent.com/find/assist)**

**Or contact the test and measurement experts at Agilent Technologies**

(During regular or local business hours)

**United States:**

(tel) 1 800 452 4844

**Canada:**

(tel) 1 877 894 4414

(fax) (905) 206 4120

**Europe:**

(tel) (31 20) 547 2000

**Japan:**

(tel) (81) 426 56 7832

(fax) (81) 426 56 7840

**Latin America:**

(tel) (305) 267 4245

(fax) (305) 267 4286

**Australia:**

(tel) 1 800 629 485

(fax) (61 3) 9272 0749

**New Zealand:**

(tel) 0 800 738 378

(fax) 64 4 495 8950

**Asia Pacific:**

(tel) (852) 3197 7777

(fax) (852) 2506 9284

**Product specifications and descriptions in this document subject to change without notice.**

**Copyright © 2000 Agilent Technologies**

**Printed in USA 09/00**

**5980-1916E**



**Agilent Technologies**

Innovating the HP Way